

(12) **UK Patent Application** (19) **GB** (11) **2 243 381** (13) **A**

(43) Date of A publication 30.10.1991

(21) Application No 9108244.6
 (22) Date of filing 17.04.1991
 (30) Priority data
 (31) 513922 (32) 24.04.1990 (33) US

(71) Applicant
Structural Panels INC
 (Incorporated in the USA - Florida)
 350 Burbank, Oldmar, Florida,
 United States of America
 (72) Inventor
Stephen C Meyerson
 (74) Agent and/or Address for Service
Raworth Moss and Cook
 36 Sydenham Road, Croydon, Surrey, CR0 2EF,
 United Kingdom

(51) INT CL⁵
 E04B 1/68
 (52) UK CL (Edition K)
 E1D DF112 DLEKM2 DLEQW2 D193 D2141 D401
 D402 D421 D501

(56) Documents cited
 GB 2142670 A GB 1347401 A GB 1277965 A
 WO 86/05224 A US 4769963 A

(58) Field of search
 UK CL (Edition K) E1D DF112 DLEKMCV DLEKMDV
 DLEKMNV DLEKMSV DLEQWCV DLEQWDV
 DLEQWNV DLEQWSV
 INT CL⁵ E04B

(54) **Building panel joint**

(57) A joint comprises, a ramp 20, pocket 18, which may contain a sealant (34, figures 9 and 10 not shown), an interlocking wedge element 19 and a centering stabilizer 21. In use two insulated panels 11 are locked together by a snap fit causing the wedge 19 to yieldably move over the ramp 20 into the pocket 18 causing the sealant (34), positioned in pocket 18, to extrude forming a gasket between the pocket walls 25 and the wedge 19. The wedge 19 may be formed on one edge of a panel, figure 8, or alternatively may be formed on both sides of an 'I' beam 42 interposed between two panels, figure 15.

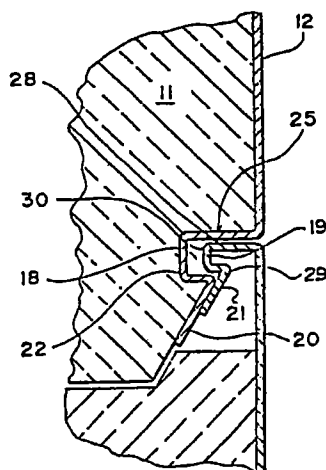

FIG. 8

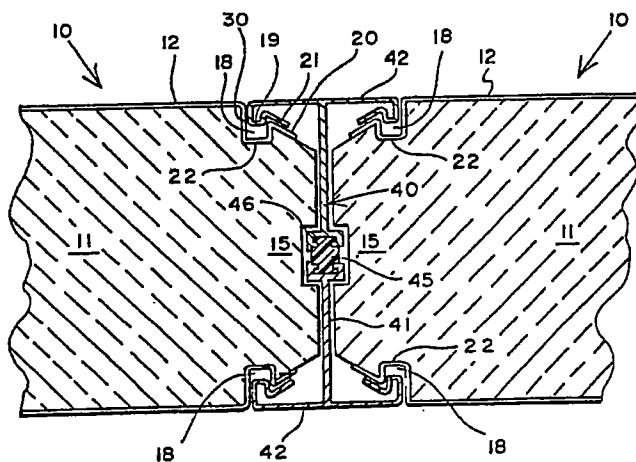

FIG. 15